

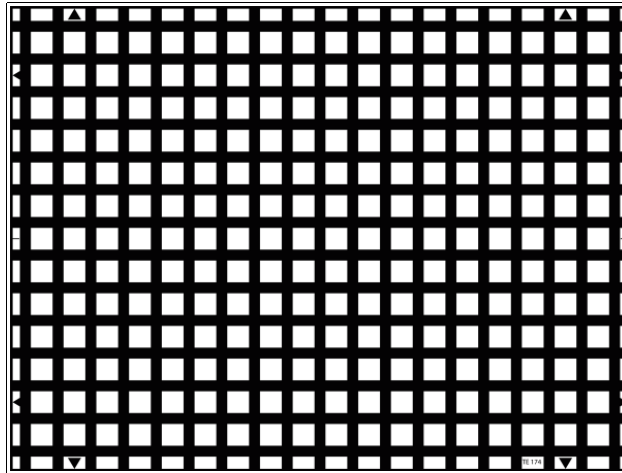

REGISTRATION TEST CHART

REFLECTANCE



The test chart is designed for determining the relative horizontal and vertical offset which can exist between the primary R, G, B signals.

In CCD cameras, any offset which may exist are mainly due to transversal optical aberration as the analysers themselves, positioned with great precision by means of a standard lens, introduce no significant offset.

The test chart has 14 horizontal and 19 vertical black lines on a white background. The lines have a width of 1.3% of the picture height.

Measuring equipment

B/W monitor

Video delay, lines switchable in 10 ns steps with a total delay of more than 200 ns

Differential video amplifier

Measurement conditions

The camera setting must be as follows:

Measurements are made on the RGB output signal

Gamma correction: unimportant

Contour correction: OFF

Color correction: OFF

The RGB signal levels are set between 50% and 100%

Iris: Fully open (if one of the RGB pictures is not sharp enough then set up the iris (F stop) to another value and refocus the lens.



Measurement procedure

The measurement equipment is connected as follows:

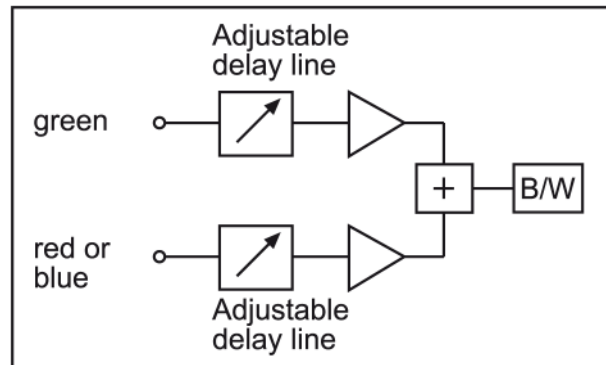

It is recommended that the measurements be made with the zoom lens setting on 'wide angle' and 'tele'. In some lenses, the maximum errors in fact appear in the 'telezoom'.

With the wide angle setting, the test pattern dimensions will for example be: 800x600, with the 'tele' setting: 400x300 (A460: 460x345 mm).

With the camera correctly focused on the test chart and for given zoom setting, the image is observed on a B/W monitor. By activating the delay lines, two vertical lines of the R-G (or B-G) image are superposed in a given area of the picture. The convergence error is then read out directly on the image defined as follow:

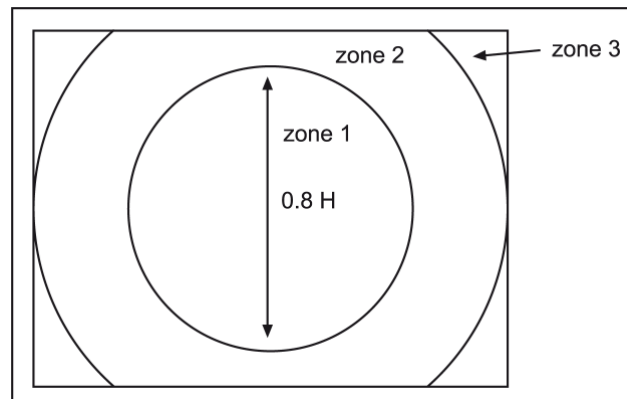

- 1) With a circle equal to 80% of the picture height (zone 1)
- 2) outside zone 1 and within a circle of a diameter equal to 100% of the picture width (zone 2)
- 3) on the remnant to the picture (zone 3)

Presentation of results

For the three zones, the maximum errors measured are recorded. The results are expressed in % of the image height and also in ns, simultaneously. Both the lens type and zoom setting must be indicated.

	R-G	B-G		R-G	B-G		R-G	B-G
Zone 1	x ns	x ns	Zone 2	x ns	x ns	Zone 3	x ns	x ns
	xx %	xx %		xx %	xx %		xx %	xx %